

## Experimental research on phytomass suitable for production of biogas

M. PASTOREK<sup>1</sup>, J. KÁRA<sup>2</sup>, Z. PASTOREK<sup>1</sup>

<sup>1</sup>*Department of Technological Equipment of Buildings, Faculty of Engineering, Czech University of Life Sciences Prague, Prague, Czech Republic*

<sup>2</sup>*Research Institute of Agricultural Engineering, Prague, Czech Republic*

### Abstract

PASTOREK M., KÁRA J., PASTOREK Z. (2015): **Experimental research on phytomass suitable for production of biogas.** Res. Agr. Eng., 61: 129–133.

The structure of the dry material plant is made up of a cell tissues system. The walls of the cells are formed by cellulose and lignin, ingredients difficult to biodegrade. Therefore, the aim of the breeders performed a variety of energy plants, providing a high yield of dry matter in the green state. This applies particularly to herbs, grown on agricultural and arable land (for example cereals, maize, sorghum, hemp, amaranthus, mallow, sugar beet, potatoes, fodder crops on arable land, permanent grassland and other). The subject of the experiment was to evaluate selected varieties of maize and sorghum and to determine the suitability of the materials on the device model for anaerobic fermentation mixed with beef slurry, and ferment from the biogas plant. Among the varieties of maize there are the significant differences in the production of biogas in the same conditions. Of the three maize varieties (Fixxif, Saxxo, Benicia), the most powerful was Saxxo.

**Keywords:** maize; variety; sewer gas; methane

Plant biomass (phytomass) has become an indispensable material for agricultural biogas plants. The name used for these materials is plants with herbal character, unlike wood. Their use in agricultural biogas plants requires certain conditions necessary for the biodegradation of organic plant matter. This process is described in the literature by many authors (KARPENSTEIN-MACHAN 2005; ECKEL et al. 2006; STRAKA et al. 2006; DOHLER et al. 2009; VETTER et al. 2009; DOHLER, PATERSON 2011; PASTOREK et al. 2013) (Fig. 1).

The structure of the dry material plant is made up of a cell tissues system. The walls of the cells are formed by cellulose and lignin, ingredients difficult

to biodegrade. Therefore, the aim of the breeders performed a variety of energy plants, providing a high yield of dry matter in the green state. This applies particularly to herbs, grown on agricultural and arable land (cereals, maize, sorghum, hemp, amaranth, mallow, sugar beets, potatoes, fodder crops on arable land, permanent grassland and other).

The result of anaerobic fermentation determines not only the selection of the appropriate herbs, but also its processing or mixing before the entry into the fermenter.

In agricultural biogas plants, in addition to purposely cultivated energy herbs, exclusively the livestock manure is used which is according to the law

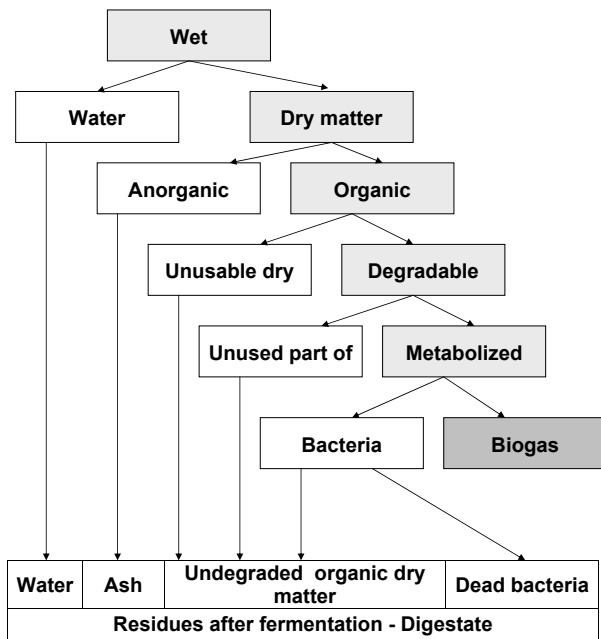

Fig. 1. Fractionation of wet material in the fermenter (PASTOREK et al. 2013)

about fertilizers No. 156/1998 Coll., as amended, livestock excrements and vegetable waste from agricultural production. The suitability of the material for the anaerobic fermentation in the fermenter assessed the content of organic solids, and volatile compounds in it, according to the proportional representation of carbon, nitrogen, phosphorus and potassium (600:20:5:1). (STRAKA et al. 2003; PASTOREK et al. 2004; MUŽÍK, KÁRA 2008).

The subject of described experiments was to evaluate selected varieties of maize and sorghum and to determine the suitability of the materials on model

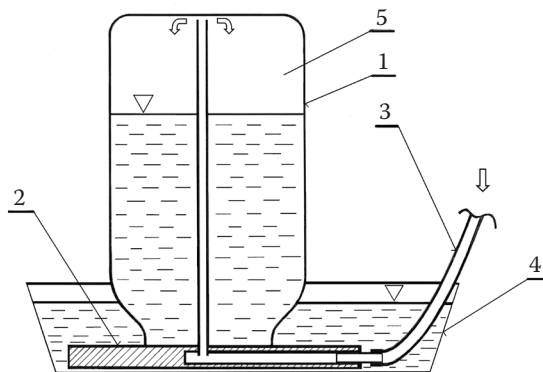

Fig. 2. Equipment for measuring of biogas production  
1 – glass bottle; 2 – basic plate; 3 – input biogas; 4 – water basin; 5 – biogas

of the device for anaerobic fermentation, mixed with beef slurry and ferment from the biogas plant.

## MATERIAL AND METHODS

For the experiments the following samples of plant material were selected: maize varieties Bonicia, Fixxif and Saxxo and sorghum.

Mixed material for laboratory processing was prepared from the three components:

- beef slurry
- ferment from a biogas plant (Kněžice, Czech Republic)
- plant material (maize, sorghum).

Control sample contained only beef slurry and ferment. For the experimental monitoring of anaerobic process laboratory equipment (Fig. 2) of the Research Institute of Agricultural Engineering (RIAE), Prague, Czech Republic was used. It is a system of nine fermenters of 3-litre volume (custom design, RIAE, Prague, Czech Republic), stored in the tempered water bath. Produced biogas is measured by

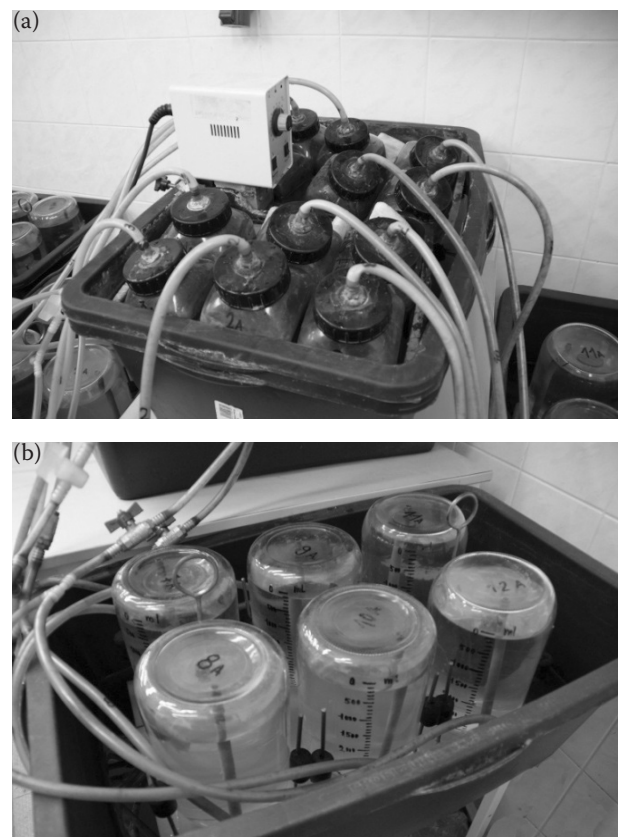

Fig. 3. Experimental (a) fermenters (1-l volume) and (b) gas-holders (3-l volume)



Fig. 4. Equipment for biogas analysing (analyser AIR LF)

lysed and measured by AIR LF equipment (AIR LF, Prague, Czech Republic) (Fig. 4).

### RESULTS AND DISCUSSION

The processed measured results are shown in the following figures. The results in Fig. 5 suggest that the addition of maize to the mixture has always a positive impact on the production of biogas. The largest impact was that of variety Saxxo (Fig. 5b). The expected positive result of crushed maize and sorghum should not be compared with a control sample in the case of varieties Fixxif and Benicia (Fig. 6). Developments of relation between the content of methane and of carbon dioxide for various varieties of maize are shown in Fig. 7.

special equipment (custom design, RIAE, Prague, Czech Republic) (Fig. 3). The value of production of biogas is verified in the daily interval, recorded and graphically evaluated. Biogas composition was ana-

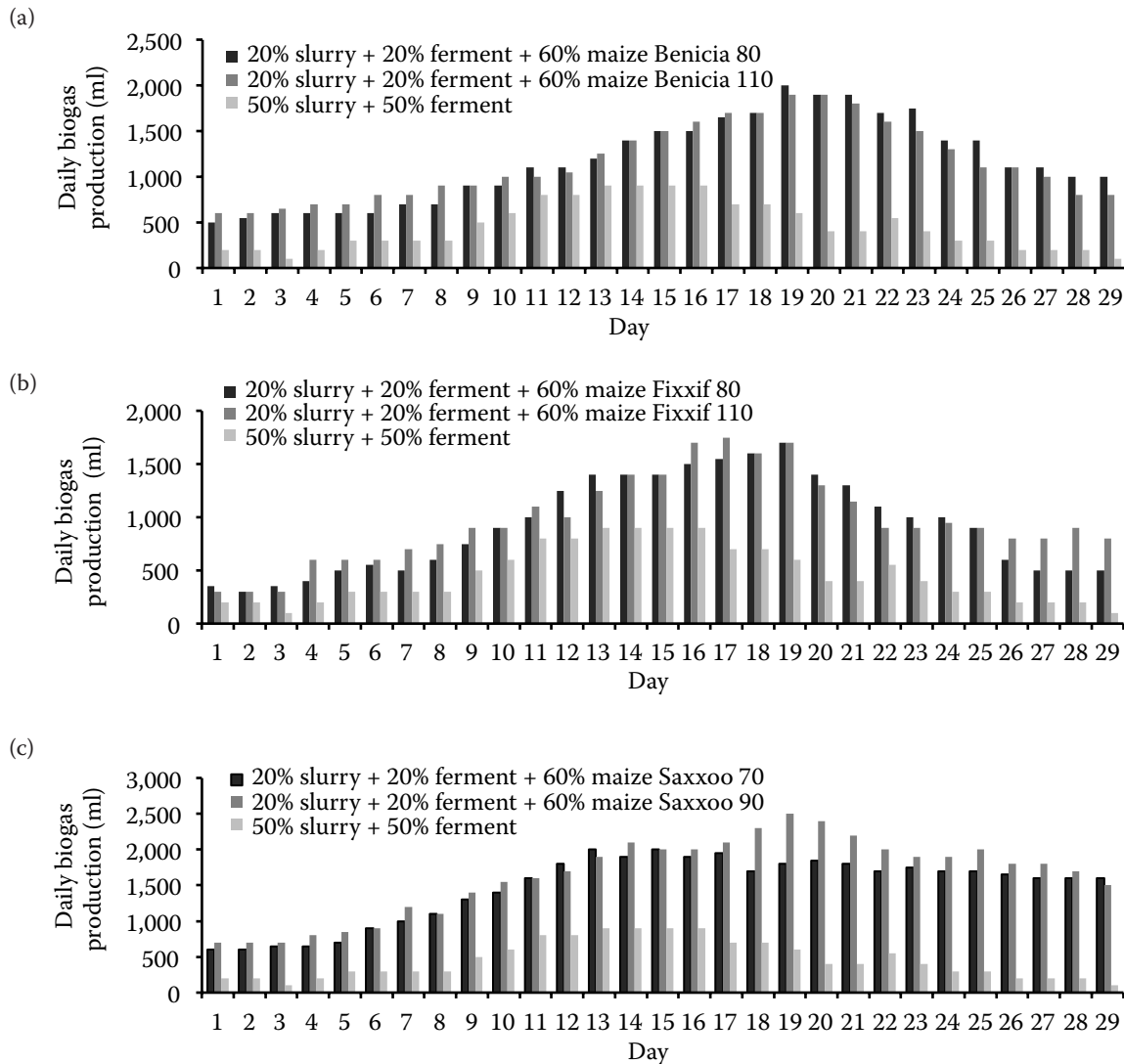

Fig. 5. Biogas daily production at biogas plant Kněžice with maize variety (a) Benicia, (b) Fixxif and (c) Saxxo

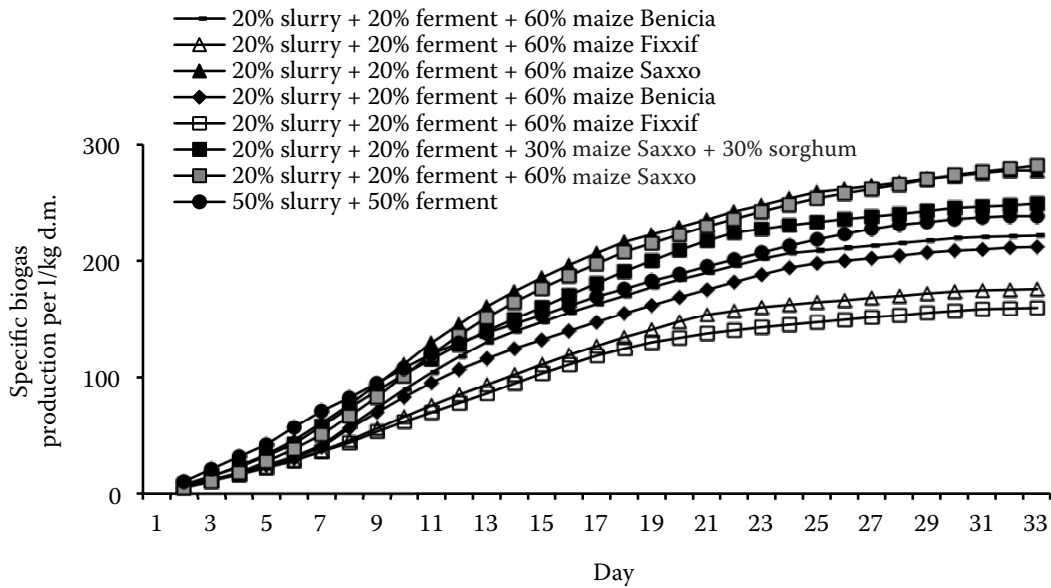

Fig. 6. Biogas production from ferment, maize and sorghum

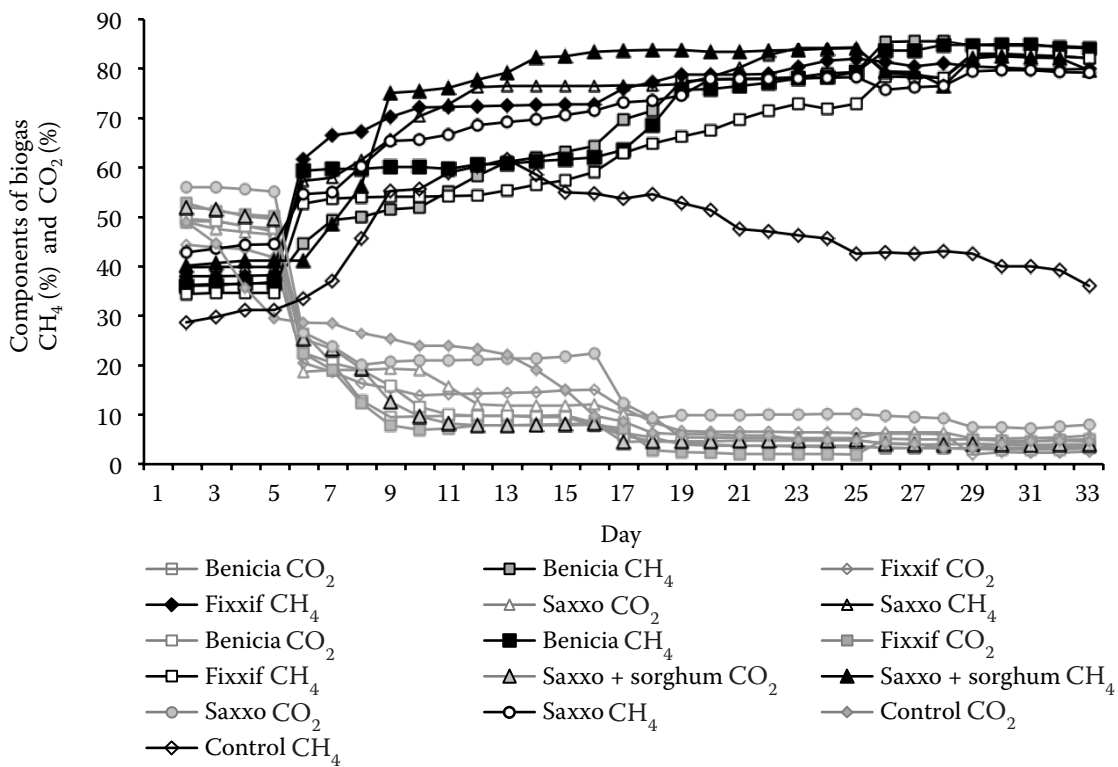

Fig. 7. Relation between methane and carbon dioxide content for various maize varieties and sorghum

### CONCLUSION

The variety of maize has a certain influence on the production of biogas by anaerobic fermentation. From the three monitored varieties (Fixxif, Saxxo, Benicia), the best results were observed with Saxxo

mixed with beef slurry, and ferment from the biogas plant. At present, the higher number of bred corn varieties, which could give good yields and a shorter growing season and lower average temperature during the growing season. It is likely that yields per hectare of corn in our climate will continue to increase.

**References**

- Dohler H., Eckel H., Boxberger J. (2009): Die Landwirtschaft als Energieerzeuger. Darmstadt, KTBL.
- Dohler H., Paterson M. (2011): Biogas in der Landwirtschaft- Stand und Perspektiven. Darmstat, KTBL.
- Eckel H. et al. (2006): Datensammlung Energiepflanzen. Darmstadt, KTBL.
- Karpenstein-Machan M. (2005): Energiepflanzenbau für Biogasanlagenbetreiber. Frankfurt am Main, DLG Verlags GmbH.
- Mužík O., Kára J. (2008): Possibilities of Biogas Production and Utilization. In: Farmář Speciál. Prague, Profi Press.
- Pastorek Z., Kára J., Jevič P. (2004): Biomasa – obnovitelný zdroj energie. Prague, FCC Public.
- Pastorek M., Pastorek Z., Kára J. (2013): Utilization of plant matter for biogas production. In: Proceedings from Trendy v zemědělské technice, Sept. 3–6, 2013. Prague, Czech University of Life Sciences Prague.
- Straka F. et al. (2003): Bioplyn – příručka pro výuku, projekci a provoz bioplynových systémů. Říčany, GAS s.r.o.
- Vetter A. et al. (2009): Anbausysteme für Energiepflanzen. Frankfurt am Main, DLG Verlags GmbH.

Received for publication November 5, 2013

Accepted after corrections April 30, 2014

*Corresponding author:*

Ing. MICHAL PASTOREK, Czech University of Life Science in Prague, Faculty of Engineering,  
Department of Technological Equipment of Buildings, Kamýcká 129, 165 21 Prague 6-Suchbát, Czech Republic  
phone: + 420 224 383 198, e-mail: lojdova@tf.czu.cz